

TOLL FREE

1-866-217-4066

TEL

704-994-5280

FAX

704-230-1468



shown in stainless with poster door

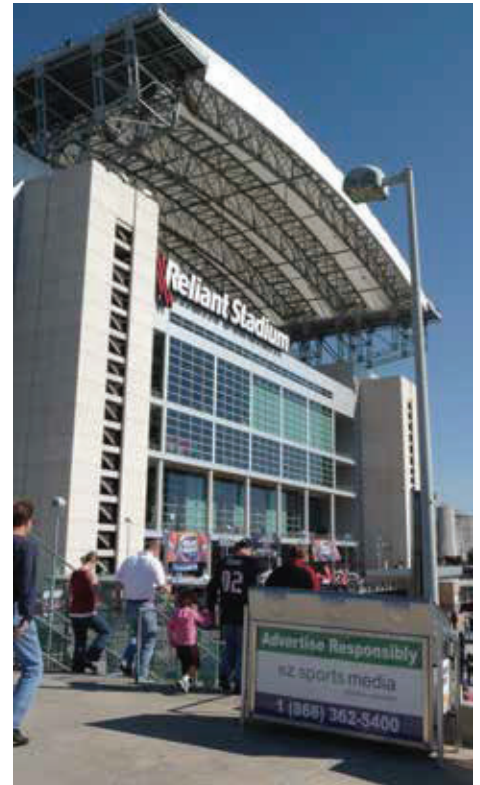

shown in stainless with poster door



shown painted with poster door



shown in stainless with solid front door

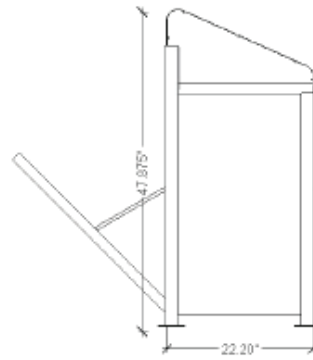
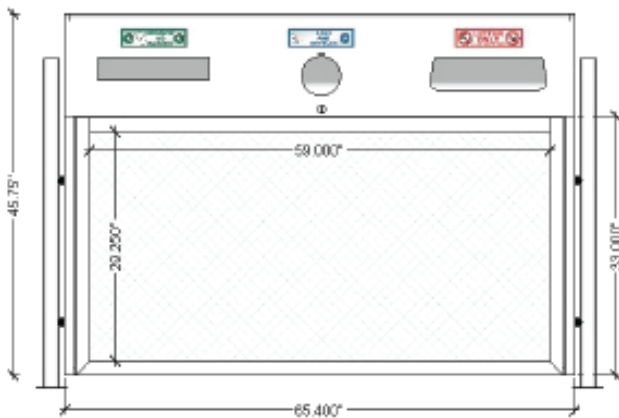
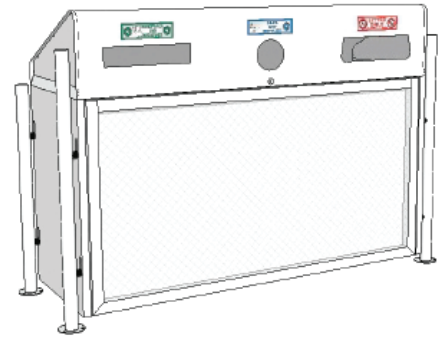
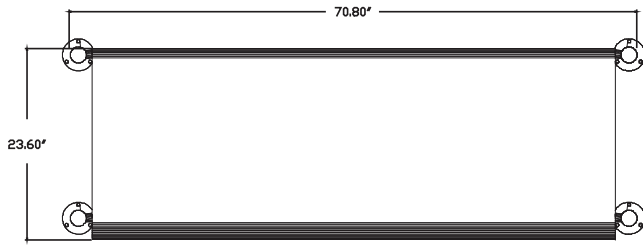

one (1) door opening

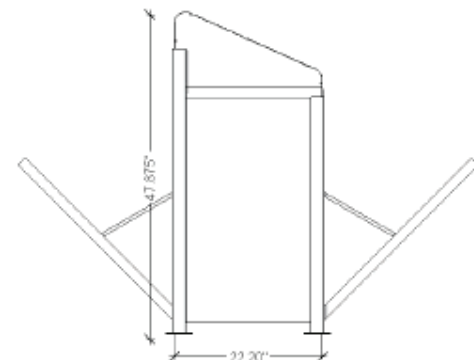

two (2) door opening

- **Model:** EL-003-S1-SC : stainless one poster door
EL-003-S1-SC-SLD : stainless one solid door
EL-003-S2-SC : stainless two poster doors

EL-003-P1-SC : painted one poster door
EL-003-P1-SC-SLD : painted one solid door
EL-003-P2-SC : painted two poster doors
- **Material:** Body - stainless or painted galvaneal sheet
Door - aluminum
Legs, hinges & hardware - stainless
- **Liner:** 19" x 19" x 28" Plastic liner
Capacity: 144 litre / 38 US gal
Material: Polyethylene
- **Dimensions:** 24.5" (D) X 72.75" (W) X 50" (H)
- **Board Messaging:** Poster size: 60.75" X 31.5"
Viewable area: 59.25" X 29.25"
- **Weight:** 285 lbs (130 kg)
- **Lock:** Quarter turn cam lock
universal key or turn knob
- **Installation:** Surface mounted using anchors