

TOLL FREE

1-866-217-4066

TEL

704-994-5280

FAX

704-230-1468

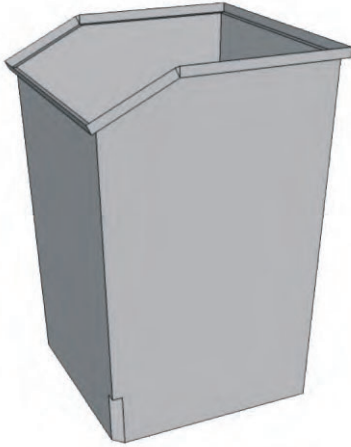

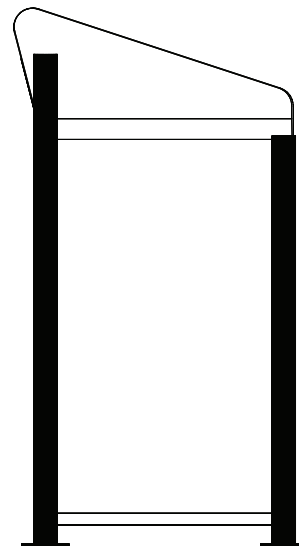
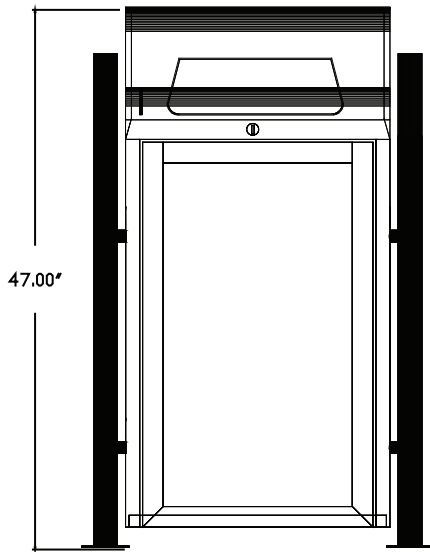
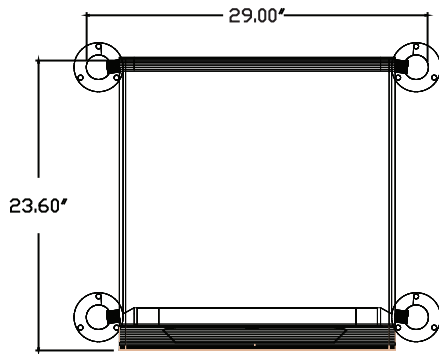

- Model: EL -001 S / P
- Material: S - Stainless Steel
P - Zinc Plated Steel
- Finish: Brushed stainless finish
Or powder coated finish
- Liner: AC-001(05-02-07)
19" x 19" x 28" Plastic liner
Capacity: 144 litre / 38 US gal
Material: Polyethylene
- Door: Optional side hinged door available
- Dimensions: 23.6"(d) x 29"(w) x 47"(h) approx.
- Openings: 100mmx380mm "LITTER ONLY"
3.9"x15" "LITTER ONLY"
- Lock: Cam style mechanism with key
- Weight: Approximately 150lbs.
- Installation: Bolted down or free standing
- BoardMessaging: Area per single face:17.5"x30"